



Tovačovská 3488/28,  
750 02 Přerov  
CZECH REPUBLIC  
Tel.: 00420 - 581 - 746256-58  
Fax: 00420 - 581 - 746255  
E-Mail: [LEVIOR@LEVIOR.CZ](mailto:LEVIOR@LEVIOR.CZ)  
Web: [www.levior.cz](http://www.levior.cz)

## TELESCOPIS LADDER

**Item number: 48410**



### OPERATING AND INSTALLATION INSTRUCTIONS



## IMPORTANT INFORMATION BEFORE USE

This instruction manual describes the safe use of the telescopic ladder.

Read all of this leaflet carefully before using your telescopic Ladder use.

1. Ensure you are fit enough to use the ladder. Certain medical conditions, medication, alcohol or drug use could make it unsafe to use the ladder.
2. When transporting the ladder on roof bars or in the car, ensure they are suitably placed to prevent damage.
3. Inspect the ladder after delivery and before first use to confirm conditions and operation of all parts.
4. At the start of each working day, before using the ladder, visually inspect it for damage and to ensure that it is safe.
5. For professional users, regular periodic inspection is required (HSE Regulations)
6. Ensure the ladder is suitable for the task.
7. Do not use a damaged ladder.
8. Remove any contamination from the ladder such as wet paint, mud, oil or snow.
9. Before using a ladder at work, a risk assessment should be carried out respecting BOZP.

## ASSEMBLY OF THE LADDER

The ladder is equipped with a cross heel, which must be fitted before using the ladder. Screwdrivers are required for assembly.

### Fixing the feet in three steps:

1. Fix the two feet (H-1) on the transverse heel.
2. Insert the cross heel (H) first into the ladder sides (A).
3. Then screw the cross heel firmly to both sides of the ladder.

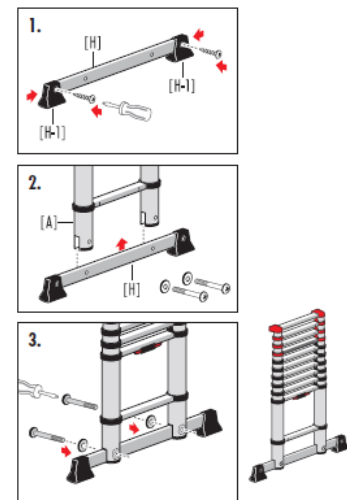

## POSITIONING AND ERECTING THE LADDER

1. Inclination angle should not exceed 75 degrees.
2. Ladder shall be on an even, level and unmovable base. 
3. Leaning ladder should lean against a flat non-fragile surface and should be secured before use, e.g. tied or use of suitable stability device.
4. When positioning the ladder take into account risk if collisions with the ladder, e.g., from pedestrians, vehicles or doors. If possible, lock or block doors (but not emergency exits) and windows in the ladder work area.

5. Identify any electrical risks in the work area, such as overhead lines or other exposed electrical equipment.



6. Ladder shall be stood on its feet, not the rung or steps.

7. The ladder must not be placed on a slippery surface (e.g., ice, a slippery surface or a heavily soiled solid surface) unless other effective measures are taken to prevent the ladder from slipping or to ensure that soiled surfaces are adequately cleaned.



8. Only one person can be on the ladder.



## USING THE LADDER

1. Do not exceed the maximum total load (150 kg).



2. Do not overreach, users should keep their buckle (navel) inside the stiles and both feet on the same step/rung throughout the task.
3. Do not step off a leaning at a higher level without additional security, such as tying off or use of a suitable stability device.

4. Do not use standing ladder of access to another level.



5. Do not stand on the top three steps/rungs of a leaning ladder.
6. Ladders should only be used for light and short-term work.
7. Do not use the ladder outdoors in adverse weather conditions, e.g., strong wind, ice.
8. Take precautions against children playing on the ladder.
9. When ascending and descending, face the ladder.
10. Keep a secure grip on the ladder when ascending and descending.
11. Do not use the ladder as a bridge.
12. Wear suitable footwear when climbing ladders.
13. Avoid excessive lateral loads on the ladder, e.g., drilling into bricks and concrete.



14. Do not spend long periods of time on the ladder without regular breaks (tireless is a risk)  
Telescopic ladders used for access to a higher level should be extended at least 1 m above the landing point.

15. The equipment carried when using the ladder should be light and easy to handle.

## LAYOUT OF THE LADDER

Automatic locking: each rung of the ladder has locking indicators that are automatically inserted into the grooves in the ladder columns when the ladder is extended.

The lock status of the two black indicators on the side of each partition will be displayed.

- Locked position: there is a gap between the indicator and the bar.

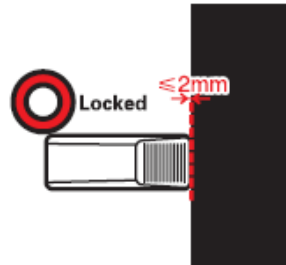

- Unlocked position: the indicators are located directly on the leg.

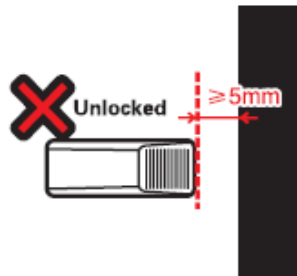

## COMPLETE EXTENSION AND RETRACTION OF THE LADDER

### Extending the ladder:

- Ladder on a firm and level ground move one the lowest rung.
- The lowest rung off and check if the button are locked. Repeat the process with each of the next higher rung, until the arms are completely extended.

### Retracting the ladder:

- Ladder on a firm and level ground move one the lowest rung.
- Unlock the indicators and pull down the rung.

**Caution: Always check that all buttons are on the exact position “locked”, before you climb on the ladder.**

## WARRANTY CERTIFICATE

### TELESCOPIS LADDER

Date of manufacture.....

The above-mentioned mixer has been manufactured in accordance with current design and technological documentation and in accordance with current corporate standards.

#### WARRANTY TERMS:

1. The guarantee is provided for the correct operation of the mixer for a period of 24 months from the date of purchase.
2. The warranty period shall not exceed a period of 24 months from the date of shipment mixers to distributor.
3. Warranty obliges manufacturer to eliminate production defects discovered by users / defective design, improper use of material / - by the deadline of 30 days from the date of fault detection and reporting complaints to users (sellers), together with this Warranty Certificate.
4. In case of electric engine failure, the user is obligated to send by mail the entire drive together with valid warranty certificate, to the address of mixer manufacturer.
5. The guarantee becomes invalid if: improper storage, use that does not match the operating instructions, repairs and changes without the consent of the manufacturer.
6. During 10 days from the date of purchase is necessary to check whether the mixer is complete and that there is no mechanical damage. Subsequent complaints regarding the completeness and damage during transport will not be considered.
7. Blank and unsigned warranty certificate is invalid
8. In case, the claim is not valid, all costs associated with repairing are covered by the user.

Serial number .....

.....

(Date of purchase + sign of seller)

Tovačovská 3488/28, 750 02 Přerov  
CZECH REPUBLIC  
Tel.: 00420 - 581 - 746256-58  
Fax: 00420 - 581 - 746255  
E-Mail: LEVIOR@LEVIOR.CZ  
Web site: www.levior.cz

.....

(Specify the number of manufacturing a label located in the cover of the drive)