

FESTA

NOVINKY **2026**



FESTO
POWER X TOOLS



FESTO
INDUSTRY



FESTO



FESTO
Garden



FESTO
AQUATIC

KLADIVO VRTACÍ A SEKACÍ SDS+ AKU BRUSHLESS

hloubkový doraz

otáčky bez zatížení 1.0-1150 min⁻¹

hmotnost bez baterie 2,7 kg

BMP / příklep 0-5100 / 2,8 J

úchyt SDS+

SDS+ upínací hlava nástroje

přepínač směru otáčení

ergonomická pogumovaná rukojeť pro pohodlný a bezpečný úchop

přepínání režimu

Doporučené příslušenství

SHARE
20V
Li-ion
technology

baterie* 2 Ah - 28080
4 Ah - 28081
8 Ah - 28083

nabíječka* 2,4 A - 28085
4,0 A - 28086



FESTA
POWER X TOOLS



*baterie a nabíječka není součástí balení

Č.p. 28026



UTAHOVÁK RÁZOVÝ 1/2" AKU BRUSHLESS

1/2"

otáčky bez zatížení 0-2800 min⁻¹

hmotnost bez baterie 1,2 kg

kroučící moment 400 Nm

počet rázů 0-3500 bpm

ergonomická pogumovaná rukojeť pro pohodlný a bezpečný úchop

LED

součást balení: adaptér 18616

3 level torque

3 úrovně kroučícího momentu:
250Nm
320Nm
400Nm

0 1/4" ↔ 0 1/2"

Doporučené příslušenství

SHARE
20V
Li-ion
technology

baterie* 2 Ah - 28080
4 Ah - 28081
8 Ah - 28083

nabíječka* 2,4 A - 28085
4,0 A - 28086



FESTA
POWER X TOOLS



*baterie a nabíječka není součástí balení

Č.p. 28023



SEKAČKA NA TRÁVU AKU BRUSHLESS

šířka sekání
40 cm

nastavitelná
výška
25-70 mm

objem koše
45 l

napájení
2x20 V

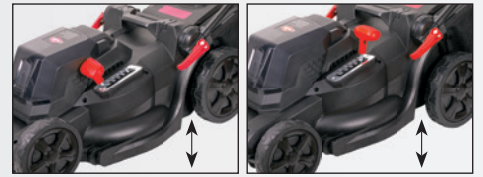

nastavitelná výška v šesti stupních
25-70 mm



SHARE
20V
Li-ion
technology

Doporučené příslušenství

2 Ah - 28080

baterie* 4 Ah - 28081

8 Ah - 28083

nabíječka* 2,4 A - 28085

4,0 A - 28086



FESTA
POWER X TOOLS



*baterie a nabíječka není součástí balení

Č.p. 28601	sekačka na trávu	1
Č.p. 28671	náhradní nůž pro 400 mm 28601	1

ZAHRADNÍ FOUKAČ "FUKAR" AKU BRUSHLESS

rychlost proudění
vzduchu
108 km/h
148 km/h

objem vzduchu
540 m³/h
744 m³/h

hmotnost
1,8 kg

napájení
20 V



SHARE
20V
Li-ion
technology

Doporučené příslušenství

2 Ah - 28080

baterie* 4 Ah - 28081

8 Ah - 28083

nabíječka* 2,4 A - 28085

4,0 A - 28086



FESTA
POWER X TOOLS



*baterie a nabíječka není součástí balení

Č.p. 28640		1
------------	--	---

PILA ŘETĚZOVÁ AKU BRUSHLESS

délka lišty
400 mm

rychlost řezu
12 m/s
20 m/s

napájení
2x20 V

hmotnost
4,8 kg



ukazatel stavu
baterií



FESTA
POWER X TOOLS



*baterie a nabíječka není součástí balení

Č.p. 28620	pila řetězová		1
Č.p. 28678	náhradní řetěz pro 28620		1
Č.p. 28679	náhradní lišta pro 28620		1

Doporučené příslušenství

SHARE
20V
Li-ion
technology

baterie*
2 Ah - 28080
4 Ah - 28081
8 Ah - 28083

nabíječka*
2,4 A - 28085
4,0 A - 28086



PILA ŘETĚZOVÁ, JEDNORUČNÍ AKU BRUSHLESS

délka lišty
150 mm

rychlost řetězu
7,4 m/s

napájení
20 V

hmotnost
1,3 kg



FESTA
POWER X TOOLS



*baterie a nabíječka není součástí balení

Č.p. 28625	pila řetězová		1
Č.p. 28681	náhradní řetěz pro 28625		1
Č.p. 28682	náhradní lišta pro 28625		1

Doporučené příslušenství

SHARE
20V
Li-ion
technology

baterie*
2 Ah - 28080
4 Ah - 28081
8 Ah - 28083

nabíječka*
2,4 A - 28085
4,0 A - 28086



NŮŽKY NA ŽIVÉ PLOTY AKU

délka lišty
670 mm

max. průměr stříhu
Ø15 mm

napájení
20 V

hmotnost
2,3 kg



bezpečnostní spínač



otočná rukojeť

Doporučené příslušenství

SHARE
20V
Li-ion
technology

baterie* 2 Ah - 28080
4 Ah - 28081
8 Ah - 28083
nabíječka* 2,4 A - 28085
4,0 A - 28086



FESTA
POWER X TOOLS

1300 min⁻¹
NO LOAD SPEED

20V

610 mm

electro STOP

2,3 kg

max. 15 mm

*baterie a nabíječka není součástí balení

Č.p. 28630

1

NŮŽKY NA ŽIVÉ PLOTY A TRÁVU AKU

délka lišty
200 mm

max. průměr stříhu
Ø7,5 mm

napájení
20 V

hmotnost
1,1 / 1,4 kg



200 mm

92 mm

FESTA
POWER X TOOLS

1200 min⁻¹
NO LOAD SPEED

20V

200 mm

92 mm

1,1 kg
1,4 kg

max. 7,5 mm

*baterie a nabíječka není součástí balení

Č.p. 28635

1

SHARE
20V
Li-ion
technology

Doporučené příslušenství
baterie* 2 Ah - 28080
4 Ah - 28081
8 Ah - 28083
nabíječka* 2,4 A - 28085
4,0 A - 28086



KŘOVINOŘEZ AKU BRUSHLESS

otáčky
bez zatížení
5000 min⁻¹
6500 min⁻¹
7500 min⁻¹

ø sekání
255 mm

napájení
2x20 V

hmotnost
4 kg



ukazatel stavu
baterií

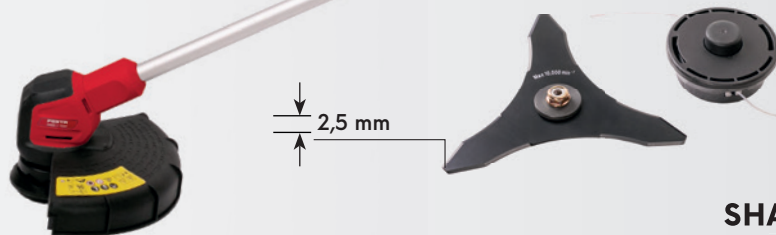

2,5 mm



SHARE
20V
Li-ion
technology

Doporučené příslušenství

2 Ah - 28080
baterie* 4 Ah - 28081
8 Ah - 28083
2,4 A - 28085
nabíječka* 4,0 A - 28086



06/2026

FESTA
POWER X TOOLS

255 mm
2.5 mm
BLADE
2.0 mm
STRING
2x20 V

*baterie a nabíječka není součástí balení

Č.p. 28610	křovinořez	1
Č.p. 28684	náhradní strunová hlava pro 28610	1

STRUNOVÁ SEKAČKA AKU

otáčky
bez zatížení
8500 min⁻¹

ø sekání
(struna)
250 mm

ø sekání
(čepele)
240 mm

hmotnost
bez baterie
1,8 kg



sklopná ruka



nastavitelný sklon



vodící kolečko



teleskopická a otočná rukojeť

SHARE
20V
Li-ion
technology

Doporučené příslušenství

2 Ah - 28080
baterie* 4 Ah - 28081
8 Ah - 28083
2,4 A - 28085
nabíječka* 4,0 A - 28086



*baterie a nabíječka není součástí balení

Č.p. 28615	strunová sekačka	1
Č.p. 28675	náhradní strunová hlava pro 28615	1
Č.p. 28676	náhradní hlava s plastovými noži pro 28615	1

POKOSOVÁ PILA

výkon
2000 W

otáčky
bez zatížení
5000 min⁻¹

kotouče
Ø 255 mm

napájení
230 V
50 Hz



náklon kotouče
-45° ← 0° → 45°

FESTA

ŘEZNÁ KAPACITA	
POKOSOVÝ ÚHEL x NÁKLON KOTOUČE	ŠÍŘKA MATERIÁLU x VÝŠKA MATERIÁLU
0° x 0°	305 x 90 mm
45° x 0°	216 x 90 mm
0° x 45° (L)	305 x 48 mm
0° x 45° (R)	305 x 25 mm
45° x 45° (L)	216 x 48 mm
45° x 45° (R)	216 x 25 mm



pokosový úhel
-50° ← 0° → 50°

230V
~50Hz

2000 W

5000 min⁻¹

Ø 255 mm

Č.p. 28235 pokosová pila

Č.p. 22338 kotouč pilový FESTA SK Ø 255 mm x 2,8 mm Ø 30 mm 40T



06/2026

1
1

SVÁŘECÍ INVERTOR MMA 160 A

výkon
7,3 kVA

rozsah
svářecích proudů
20 - 160 A

max. napětí
naprázdno
70 V

průměr
elektrody
Ø2,0 - 4,0 mm



FESTA



160A 230V 50Hz 2,0-4,0 mm 6kg 405x165 x270 mm

iGBT technology MMA DC

ANTI STICK ARC FORCE HOT START

napětí/frekvence:	230 V / 50 Hz
napětí naprázdno:	70 V
regulační rozsah svářecích proudů:	20 - 160 A
průměr elektrody:	2,0 - 4,0 mm
třída ochrany:	IP 21S
druh svařování:	MMA
rozměry:	405 x 165 x 270 mm
technologie:	anti-stick, Arc-force, Hot start
hmotnost:	6 kg

Č.p. 70042

1

ČERPADLO KALOVÉ

výkon
750 W

max. dopravní výška
8 m

max. hloubka ponoru
7 m

max. průtok
14000 l/h



Ø25 mm
Ø32 mm
G 1"
G 1-1/2"

spínací plovák

WESTBERG

IPX8 750W 230V ~50Hz Max. 14000 l/h Max. 25 mm Max. 8m Max. 7m MAX 35°C Ø 25 mm Ø 32 mm G1" G1 1/2" 10m

Č.p. 35355

1



PRÍSAVKA AKU

horizontální poloha
150 kg

Ø 200 mm

vertikální poloha
100 kg

USB-C



WESTBERG

Ø 200 mm 100 kg 150 kg USB TYPE C Li-ion 3.7V 2Ah

Č.p. 36330 Ø 200 mm

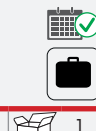

PRÍSAVKA AKU

horizontální poloha
100 kg

90 x 240 mm

vertikální poloha
40 kg

USB-C



WESTBERG

90 x 240 mm 40 kg 100 kg USB TYPE C Li-ion 3.7V 3,6Ah

Č.p. 36333 přísavka
Č.p. 36334 náhradní baterie 3,7V / 3,6 Ah



NÁHRADNÍ BATERIE Li-ion 12 V PRO VRTAČKU



FESTA
POWER X TOOLS

Li-ion 12 V 1,5 Ah



28007



Č.p. 28079

1

SADA BATERIÍ Li-ion, NABÍJEČKY A ADAPTÉRU PRO ŘEZAČKY NA POLYSTYREN



FESTA

2x baterie 37V/2200mAh
nabíječka 1,0A
držák pro uchycení



35330
35344
35345
35348

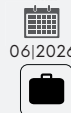

Č.p. 35349

1

ODSÁVACÍ KRYT NA ÚHLOVOU BRUSKU PRO ŘEZÁNÍ, DRÁŽKOVÁNÍ



ODSÁVACÍ KRYT NA ÚHLOVOU BRUSKU PRO BROUŠENÍ



NÁHRADNÍ HADICE PRO VYSAVAČ



FESTA
POWER X TOOLS

· Ø 32 mm
· 3 m

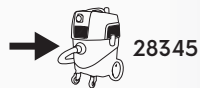

28345

Č.p. 28348



1

ROTAČNÍ TRYSKOVÝ KARTÁČ PRO TLAKOVOU MYČKU



nastavení rychlosti průtoku vody

FESTA
POWER X TOOLS



45271

Č.p. 45274



1

DRÁT PÁJECÍ TRUBIČKOVÝ



FESTA

· Ø 1 mm
· Sn 99,3%, Cu 0,7%

227 °C

Pb FREE

RoHS

Č.p. 28283 100 g



1

NÁHRADNÍ SÁČEK PRO VYSAVAČ

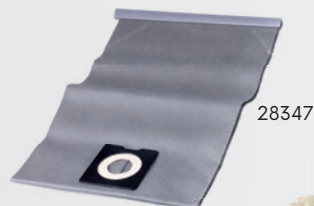

28347



28349

FESTA
POWER X TOOLS



28345

Č.p. 28347

1 ks

netkaný

1

Č.p. 28349

3 ks

papírový

1

NÁHRADNÍ FILTR PRO TLAKOVOU MYČKU



FESTA
POWER X TOOLS



3/4"

45271

Č.p. 45276

1

UNIVERZÁLNÍ TESTER BATERIÍ



WESTBERG

LCD DISPLAY

C/AA/AAA/D/
N/9V (6F22)

1.5V

Č.p. 18438

1

LASEROVÝ DÁLKOMĚŘ

FESTA

- rozsah měření 0,05 - 80 m
- přesnost měření $\pm(2 \text{ mm} + D \cdot 1/10\,000)$, jednotka měření mm/in/ft
- kontinuální měření, měření plochy, měření objemu, výpočet délky třetí strany dle Pythagorovy věty, LCD FSTN, sčítání/odčítání, max./min. měření
- maximální úložisko na 100 hodnot, čtyřřadý display LCD FSTNS s podsvícením,
- vlnová délka laseru 630 - 670 nm, pracovní teplota 0 - 40 °C
- rozměry 112 x 50 x 25 mm, hmotnost 90 g
- dodáváno s: přepravní pouzdro, 2xAAA alkalické baterie



max 80 m	$\pm(2\text{mm} + D \cdot 1/10000)$	m in ft	630 670 nm
IP 54	2x AAA		



Č.p. 26212

1

MĚŘIČ VLHKOSTI

FESTA

Elektromagnetická (indukční) metoda měření vlhkosti NDT (nedestruktivní testování)

Čtyři režimy: tvrdé dřevo (5-75 %)
měkké dřevo (5-75 %)
stavební materiály (1,5-30 %)

Vysoce kvalitní barevný podsvícený LCD displej

Rozlišení: 0,1 %

Přesnost: $\pm 0,5$ %

Napájení: vestavěná baterie Li-ion 3,7 V, 300 mAh, nabíjení USB-C

3,7V 300mAh	USB TYPE C
----------------	---------------



Č.p. 26227

1

DETEKTOR DIGITÁLNÍ

FESTA

- Železné kovy: 120 mm
- Neželezné kovy (měď): 100 mm
- Pod napětím (živý vodič): 50 mm
- Měděný vodič (≥ 4 mm): 40 mm
- Cizí tělesa (dřevěný trámek): přesný režim 20 mm / hluboký režim 38 mm

Rozměry zařízení: 146 x 72 x 24 mm

Napájení: vestavěná baterie Li-ion, 3,7 V, 300 mAh, nabíjení USB-C

3,7V 300mAh	USB TYPE C
----------------	---------------



Č.p. 26225

1

TEPLOMĚR BEZKONTAKTNÍ



FESTA

Rozsah: -50 až 700 °C
 Přesnost: ±2 °C nebo ±2 %
 Jednotky: °C / °F
 Rozlišení displeje: 0,1 °C nebo °F

9V
PP3

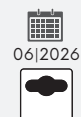

Č.p. 26229



STATIV S ROZPĚRNOU TELESKOPICKOU TYČÍ



FESTA

max
3,7 m

5/8" **1/4"**



Č.p. 26223



NÁHRADNÍ Li-ion BATERIE PRO LASER



FESTA

Li-ion
3.7V
5.2Ah

USB
TYPE C



Č.p. 26206



STATIV



FESTA

60-150 cm

5/8" **1/4"**



Č.p. 26222



Profesionální vysoce výkonné vrtáky s prémiovým TiAlN povlakem

- TiAlN (Titanium Aluminum Nitride) prémiový PVD povlak s velmi vysokou tvrdostí
- Výjimečná tepelná odolnost
- Pro vysoce náročné aplikace – obrábění nerezových a kalených ocelí
- Extrémní odolnost, snížené tření, lepší odvod tepla
- Výrazně prodloužená životnost nástroje

FESTA
INDUSTRY

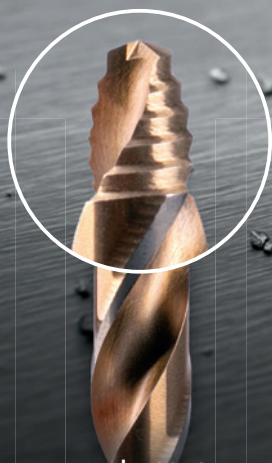

- Prémiová ocel HSS-Co5 – cobalt 5%
- Vysoká žáruvzdornost a řezný výkon
- Vhodný pro nerezové oceli, ocelové slitiny, litiny a další houževnaté materiály.

Centrovací špička
s optimalizovanou geometrií pro přesné vedení, minimální tření a plynulý vstup do materiálu

Dokonalé centrování bez potřeby předvrtání

Menší riziko sklouznutí na hladkém a oblém povrchu.

Hladký a snadný řez bez vibrací

Rychlý průchod materiálem a delší životnost nástroje

Komfortní práce s menší únavou při větším počtu otvorů.



- Kvalitní rychlořezná oceli HSS s TiAlN povlakem
- Skvělý pro plechy, profily a tenkostěnné materiály včetně nerezové oceli.

VRTÁK DO KOVU

STUPŇOVITÝ VRTÁK

FESTA
INDUSTRY

TiAlN HSS-Co5



Č.p.	22830	Ø 3,0 mm		1
Č.p.	22833	Ø 3,3 mm		1
Č.p.	22835	Ø 3,5 mm		1
Č.p.	22840	Ø 4,0 mm		1
Č.p.	22842	Ø 4,2 mm		1
Č.p.	22845	Ø 4,5 mm		1
Č.p.	22848	Ø 4,8 mm		1
Č.p.	22850	Ø 5,0 mm		1
Č.p.	22855	Ø 5,5 mm		1
Č.p.	22860	Ø 6,0 mm		1
Č.p.	22865	Ø 6,5 mm		1
Č.p.	22868	Ø 6,8 mm		1
Č.p.	22870	Ø 7,0 mm		1
Č.p.	22875	Ø 7,5 mm		1
Č.p.	22880	Ø 8,0 mm		1
Č.p.	22885	Ø 8,5 mm		1
Č.p.	22890	Ø 9,0 mm		1
Č.p.	22895	Ø 9,5 mm		1
Č.p.	22900	Ø 10,0 mm		1
Č.p.	22902	Ø 10,2 mm		1
Č.p.	22905	Ø 10,5 mm		1
Č.p.	22911	Ø 11,0 mm		1
Č.p.	22915	Ø 11,5 mm		1
Č.p.	22922	Ø 12,0 mm		1
Č.p.	22925	Ø 12,5 mm		1
Č.p.	22930	Ø 13,0 mm		1

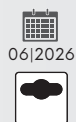

FESTA
INDUSTRY

TiAlN HSS



Č.p.	20501	4-12 mm		1
Č.p.	20502	4-20 mm		1
Č.p.	20503	5-35 mm		1
Č.p.	20504	7-40,5 mm		1



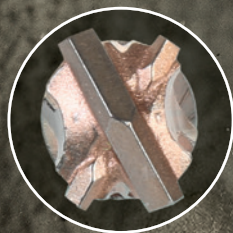

4 ŘEZNÉ HRANY

Křížový hrot tvořený čtyřmi řeznými hranami zajišťuje rychlý záběr a přesné vedení vrtáku bez podkluzování.

Stabilizuje vrták v materiálu a zaručuje čisté a přesné otvory, zlepšuje průchod i v tvrdém betonu.

Křížová geometrie hrotu snižuje vyštípnutí materiálu a zvyšuje rychlost vrtání.



4 DRÁŽKY

Čtyřdrážková spirála se širokým náběhem drážek usnadňuje odvod velkého množství vrtaného materiálu.

Snižuje tření a zvyšuje vrtací rychlost v tvrdých materiálech.

Minimalizuje vibrace a prodlužuje životnost vrtáku.

Optimalizovaná čtyřspirálová geometrie usnadňuje vrtání hlubších otvorů bez zasekávání.

VRTÁK VIDIOVÝ SDS+, ČTYŘBŘITÝ

SDS+ Cr-Mo



· beton
· cihla
· žula

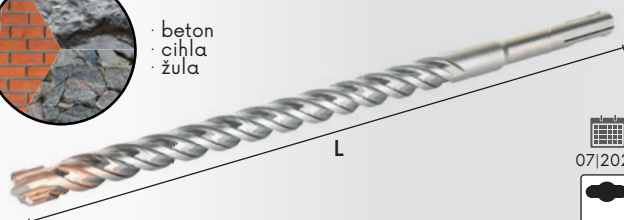

		L			
Č.p.	21610	Ø 6 mm	110 mm		1
Č.p.	21611	Ø 6 mm	160 mm		1
Č.p.	21612	Ø 6 mm	210 mm		1
Č.p.	21613	Ø 6 mm	260 mm		1
Č.p.	21614	Ø 6,5 mm	230 mm		1
Č.p.	21615	Ø 6,5 mm	300 mm		1
Č.p.	21616	Ø 8 mm	110 mm		1
Č.p.	21617	Ø 8 mm	160 mm		1
Č.p.	21618	Ø 8 mm	210 mm		1
Č.p.	21619	Ø 8 mm	260 mm		1
Č.p.	21620	Ø 8 mm	350 mm		1
Č.p.	21621	Ø 10 mm	160 mm		1
Č.p.	21622	Ø 10 mm	210 mm		1
Č.p.	21623	Ø 10 mm	260 mm		1
Č.p.	21624	Ø 10 mm	350 mm		1
Č.p.	21625	Ø 10 mm	450 mm		1
Č.p.	21626	Ø 10 mm	600 mm		1
Č.p.	21627	Ø 10 mm	1000 mm		1
Č.p.	21628	Ø 12 mm	160 mm		1
Č.p.	21629	Ø 12 mm	210 mm		1
Č.p.	21630	Ø 12 mm	260 mm		1
Č.p.	21631	Ø 12 mm	350 mm		1
Č.p.	21632	Ø 12 mm	460 mm		1
Č.p.	21633	Ø 12 mm	600 mm		1
Č.p.	21634	Ø 12 mm	1000 mm		1
Č.p.	21635	Ø 14 mm	160 mm		1
Č.p.	21636	Ø 14 mm	260 mm		1
Č.p.	21637	Ø 14 mm	350 mm		1
Č.p.	21638	Ø 14 mm	460 mm		1
Č.p.	21639	Ø 14 mm	600 mm		1
Č.p.	21640	Ø 14 mm	1000 mm		1
Č.p.	21641	Ø 16 mm	160 mm		1
Č.p.	21642	Ø 16 mm	210 mm		1
Č.p.	21643	Ø 16 mm	260 mm		1
Č.p.	21644	Ø 16 mm	350 mm		1
Č.p.	21645	Ø 16 mm	460 mm		1
Č.p.	21646	Ø 16 mm	600 mm		1
Č.p.	21647	Ø 16 mm	1000 mm		1
Č.p.	21648	Ø 18 mm	260 mm		1
Č.p.	21649	Ø 18 mm	450 mm		1
Č.p.	21650	Ø 18 mm	600 mm		1
Č.p.	21651	Ø 18 mm	1000 mm		1
Č.p.	21652	Ø 20 mm	450 mm		1
Č.p.	21653	Ø 20 mm	600 mm		1
Č.p.	21654	Ø 20 mm	800 mm		1
Č.p.	21655	Ø 20 mm	1000 mm		1
Č.p.	21656	Ø 22 mm	450 mm		1
Č.p.	21657	Ø 22 mm	600 mm		1
Č.p.	21658	Ø 22 mm	800 mm		1
Č.p.	21659	Ø 22 mm	1000 mm		1
Č.p.	21660	Ø 24 mm	450 mm		1
Č.p.	21661	Ø 24 mm	600 mm		1
Č.p.	21662	Ø 24 mm	800 mm		1
Č.p.	21663	Ø 24 mm	1000 mm		1
Č.p.	21664	Ø 26 mm	450 mm		1
Č.p.	21665	Ø 26 mm	650 mm		1
Č.p.	21666	Ø 26 mm	800 mm		1
Č.p.	21667	Ø 26 mm	1000 mm		1
Č.p.	21668	Ø 28 mm	450 mm		1
Č.p.	21669	Ø 28 mm	650 mm		1
Č.p.	21670	Ø 28 mm	800 mm		1
Č.p.	21671	Ø 28 mm	1000 mm		1
Č.p.	21672	Ø 30 mm	450 mm		1
Č.p.	21673	Ø 30 mm	650 mm		1
Č.p.	21674	Ø 30 mm	800 mm		1
Č.p.	21675	Ø 30 mm	1000 mm		1

ZÁVITOVÉ VRTÁKY - SADA



HSS + TiN →

- delší životnost a vyšší odolnost proti opotřebení
- rychlejší a přesnější řezání závitů
- vyšší řezná rychlost a nižší riziko zalomení

FESTA

1/4" 

6x

HSS TiN



M10 M8 M6 M5 M4 M3



Č.p. 20392 1/4"  1

ROTAČNÍ RAŠPLE - SADA



TiN →

- delší životnost a vyšší odolnost proti opotřebení
- snižuje tření, brání přehřívání
- hladší chod, kvalitnější opracování povrchu materiálu

FESTA

1/4" 

5x

TiN



Ø12,5 mm Ø12,5 mm Ø12,5 mm Ø12,5 mm Ø12,5 mm



Č.p. 21542 1/4"  1

ROTAČNÍ RAŠPLE OBLÁ



FESTA

Ø 100 mm Ø 22.2 mm



Č.p. 21822 Ø100 mm Ø22,2 mm  1

SUKOVNÍK DO DŘEVA S SK PLÁTKY

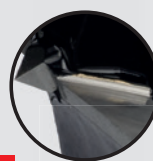

CARBIDE

Ø 10 mm

FESTA



Ø 50 mm

TC



Č.p. 21538 ø 50mm  1

DIAMANTOVÁ VRTACÍ KORUNKA SDS+



SDS+



M16

FESTA







· beton
· cihla
· žula

SDS+ M16



· použití s/ bez chlazení vodou



Č.p. 24817 Ø 72 mm 4T  1
 Č.p. 24818 Ø 82 mm 5T  1
 Č.p. 24820 Ø 102 mm 5T  1
 Č.p. 24824 upínací stopka pro korunky M16  1

PILOVÝ PLÁTEK DO OCASKY POROBETON / POROTHERM / CIHLY



FESTA

TC



· porobeton
· porotherm
· cihly



Č.p. 24317 SK 500 mm 29T  1
 Č.p. 24318 SK 550 mm 37T  1



VYSOKÁ ŽIVOTNOST A VYSOKÝ ŘEZNÝ VÝKON

KOTOUČ ŘEZNÝ, SEGMENTOVÝ DIAMANTOVÝ

FESTA
INDUSTRY

· železobeton
· cihla
· žula

· použití s/bez chlazení vodou

Č.p.	21240	Ø 125 mm x 2,4 mm	Ø 22,2 mm	1
Č.p.	21243	Ø 230 mm x 2,8 mm	Ø 22,2 mm	1

KOTOUČ ŘEZNÝ, DIAMANTOVÝ

FESTA
INDUSTRY

· keramické obklady a dlažba
· mramor

· použití s chlazením vodou

Č.p.	21246	Ø 125 mm x 1,5 mm	Ø 22,2 mm	1
------	-------	-------------------	-----------	---

KOTOUČ ŘEZNÝ, DIAMANTOVÝ

FESTA
INDUSTRY

· keramické obklady a dlažba
· mramor

1mm

ULTRA-THIN

· použití s chlazením vodou

Č.p.	21256	Ø 125 mm x 1 mm	Ø 22,2 mm	1
------	-------	-----------------	-----------	---

KOTOUČ ŘEZNÝ, BRUSNÝ NA SKLO DIAMANTOVÝ

FESTA
INDUSTRY

· sklo
· křehký
· keramika
· porcelán
· mramor

1,6mm

· použití s/bez chlazení vodou

Č.p.	21260	Ø 115 mm x 1,6 mm	Ø 22,2 mm	1
------	-------	-------------------	-----------	---

KOTOUČ LEŠTÍCÍ FILCOVÝ

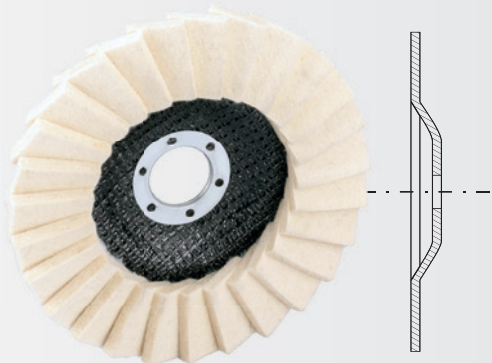

FESTA

Ø 125 mm	Ø 22.2 mm	MAX 7800 R.P.M	MAX 80 m/s
----------------	-----------------	----------------------	------------------

Č.p. 21778



KOTOUČ LEŠTÍCÍ BRUSNÝ

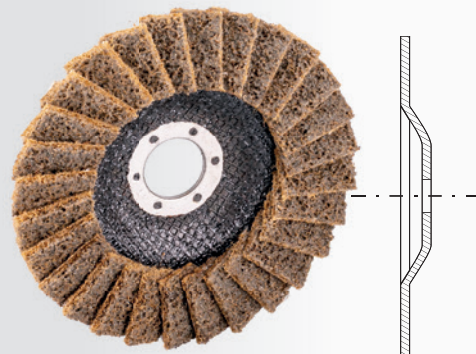

FESTA

Ø 125 mm	Ø 22.2 mm	MAX 7800 R.P.M	MAX 80 m/s
----------------	-----------------	----------------------	------------------

Č.p. 21771	P60	korundové rouno	1
Č.p. 21775	P320	karbidové rouno	1



DRŽÁK NA BRUSNÝ PAPÍR SE SUCHÝM ZIPEM



FESTA

Ø 225 mm	VELCRO
----------------	--------

VHODNÁ NÁSADA:
52010, 52011, 52012, 52020, 52030

Č.p. 31615

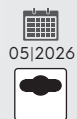

PAPÍR BRUSNÝ SE SUCHÝM ZIPEM



FESTA

Ø 225 mm	VELCRO	5X
----------------	--------	----

Č.p. 21558	P80	1
Č.p. 21560	P100	1
Č.p. 21562	P120	1
Č.p. 21565	P150	1
Č.p. 21568	P180	1



UNAŠEČ SE SUCHÝM ZIPEM

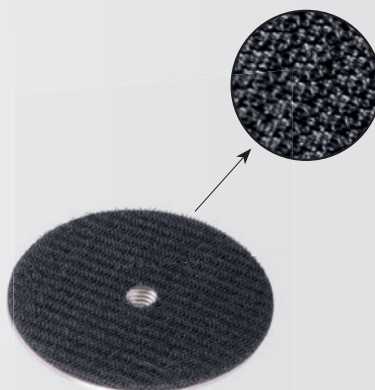

vhodné pro:



24665
24666
24667



22701
22702
22703
22704
22705
22706
22707

FESTA

ALU	Ø 100 mm	VELCRO	M14
-----	----------------	--------	-----

Č.p. 21843



KARTÁČ MISKOVÝ, VLNITÝ

WESTBERG

· pomosazený

M14



∅ 0,3



L



Č.p.	21961	∅ 100 mm	19 mm	1
------	-------	----------	-------	---

KARTÁČ HRNKOVÝ, VLNITÝ

WESTBERG

· pomosazený

M14



∅ 0,3



L



Č.p.	21962	∅ 75 mm	23 mm	1
Č.p.	21963	∅ 100 mm	26 mm	1

KARTÁČ HRNKOVÝ, COPY

WESTBERG

· patentované

M14



∅ 0,5



L



Č.p.	21965	∅ 65 mm	17 mm	1
Č.p.	21966	∅ 80 mm	18 mm	1
Č.p.	21967	∅ 100 mm	22 mm	1

KARTÁČ RADIÁLNÍ, COPY

WESTBERG

· patentované

M14



∅ 0,5



L



Č.p.	21971	∅ 115 mm	24 mm	1
Č.p.	21972	∅ 125 mm	24 mm	1
Č.p.	21973	∅ 150 mm	24 mm	1

KARTÁČ MISKOVÝ, COPY

WESTBERG

· patentované

M14



∅ 0,5



L



Č.p.	21975	∅ 100 mm	23 mm	1
------	-------	----------	-------	---

KARTÁČ KONCOVÝ, VLNITÝ

WESTBERG

· pomosazený

∅ 0,3



L



Č.p.	21981	∅ 12 mm	20 mm	1
Č.p.	21982	∅ 17 mm	25 mm	1
Č.p.	21983	∅ 25 mm	25 mm	1

KARTÁČ HRNKOVÝ, COPY

WESTBERG

· patentované

∅ 0,5



L



Č.p.	21985	∅ 75 mm	20 mm	1
------	-------	---------	-------	---

KARTÁČ OKRUŽNÍ, VLNITÝ

WESTBERG

· pomosazený

∅ 0,3



L



Č.p.	21991	∅ 50 mm	10,5 mm	1
Č.p.	21992	∅ 60 mm	14 mm	1
Č.p.	21993	∅ 75 mm	15 mm	1



4 IN 1



ČTYŘI VELIKOSTI V JEDNOM KLÍČI



Cr-Mo



CrV



4 SUPERPEVNÉ HLAVY Z Cr-Mo OCELI, ODOLNÉ TĚLO KLÍČE Z CrV OCELI

RÁČNA 120T UMOŽŇUJE ZÁBĚR UŽ OD 3° – IDEÁLNÍ PRO MONTÁŽ VE STÍSNĚNÝCH PROSTORECH

AŽ O 30 % VYŠŠÍ PŘENOS SÍLY DÍKY PEVNÉ KONSTRUKCI A PŘESNÉ RÁČNĚ

RÁČNOVÝ KLÍČ 4v1 8-10-12-13 MM



up to **30%** higher torque



Č.p. 17690 8-10-12-13  1

RÁČNOVÝ KLÍČ 4v1 14-15-17-19 MM



up to **30%** higher torque



Č.p. 17691 14-15-17-19  1

KLÍČ MOMENTOVÝ



FESTA

Cr-Mo CrV

Č.p. 17270	1/4"	5-25 Nm		1
Č.p. 17271	3/8"	20-120 Nm		1
Č.p. 17273	1/2"	40-220 Nm		1
Č.p. 17274	1/2"	60-330 Nm		1

KLEŠTĚ SIKO S TLAČÍTKEM



FESTA

CrV

0-120 mm

07/2026

Č.p. 17073	540 mm	0 - 120 mm		1
------------	--------	------------	--	---

BIT TORZNÍ T - 50 MM



FESTA
INDUSTRY

2x S2

Č.p. 18726	T45 x 50 mm		1
Č.p. 18727	T50 x 50 mm		1

NÁSTAVEC NA BITY



FESTA
INDUSTRY

CrV



72 mm

vhodný i pro rázový uťahovák

Č.p. 18595	1/4"		1
------------	------	--	---

NÁSTAVEC NA BITY A HLAVICE

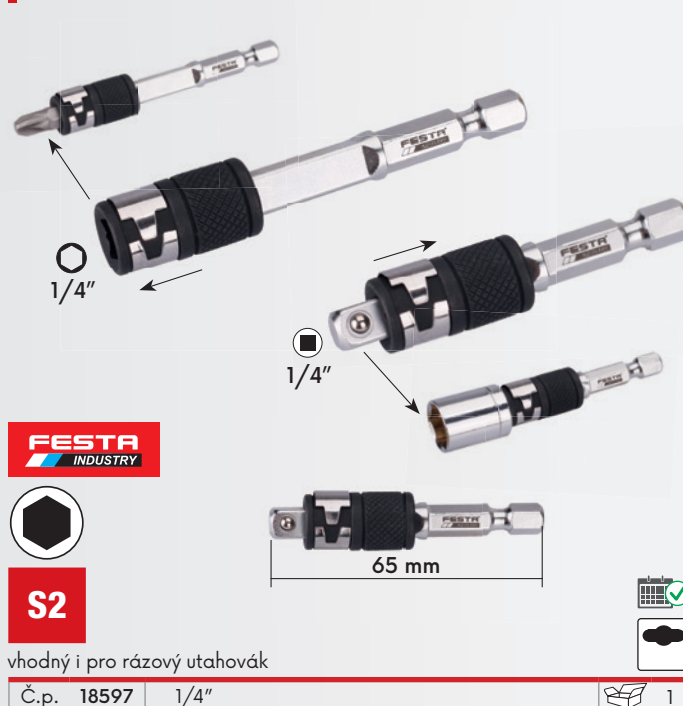

FESTA
INDUSTRY

S2

vhodný i pro rázový uťahovák

Č.p. 18597	1/4"		1
------------	------	--	---

SADA TORZNÍCH BITŮ



bity 25 mm

- ⊖ S 4 · 5,5
- ⊕ PH 1 · 2 · 2 · 3
- ⊛ PZ 1 · 2 · 2 · 3
- H 3 · 4 · 5 · 6
- ⊛ T 15 · 15 · 20 · 20 · 25 · 30

nástavec na bity 50 mm CrV
 adaptér ↔

20x S2



Č.p. 18436

1

ADAPTÉR PRO RÁZOVÝ UTAHOVÁK



Cr-Mo ↔



Č.p. 18616

1

SADA RÁZOVÝCH HLAVIC



⊖ 6 · 8 · 10 · 11 · 12 · 13 · 14 · 16 · 17 ·
 · 18 · 19 · 20 · 21 · 22 · 24 · 27 mm
 adaptér ←

17x **Cr-Mo**



Č.p. 17263

1

SADA PRODLOUŽENÝCH RÁZOVÝCH HLAVIC



⊖ 17 · 18 · 19 · 20 · 21 · 22 · 24 mm

7x **Cr-Mo**



Č.p. 17265

1

PRAVÍTKO S POSUVNÝM DORAZEM 90°/45°



FESTA

INOX
STAINLESS
STEEL

30
cm

90°

45°



Č.p. 14413



1

VYSOUVACÍ KOMBINOVANÝ NŮŽ 2v1



FESTA

náhradní čepele:
16071, 16072, 16073

Č.p. 16027

117 mm



1

VODOVÁHA



FESTA

ALU

60 mm

0.5mm/1m

270°

UV RESISTANT

U

U



Č.p. 15750

1

KLEŠTĚ NÝTOVACÍ

FESTA

Ø 2,4 mm
Ø 3,2 mm
Ø 4,0 mm
Ø 4,8 mm

Cr-Mo



Č.p. 24013



1

KLEŠTĚ NÝTOVACÍ

WESTBERG

Ø 3,2 mm
Ø 4,0 mm
Ø 4,8 mm

Cr-Mo



Č.p. 24012

BEZ NUTNOSTI VÝMĚNY PRŮCHODKY



1

ŘEZAČ TRUBEK Ø 18 MM

FESTA

INOX

18mm

· měď
· hliník
· plasty

INOX
STAINLESS
STEEL

ALU

Č.p. 16318

1

KARTÁČ NA MĚDĚNÉ TRUBKY VNĚJŠÍ/VNITŘNÍ

WESTBERG

15mm 22mm

15mm 22mm

Č.p. 22157

1

PILA JAPONSKÁ

FESTA

0,4mm

22TPI

SK5 **22TPI** **180mm**

0,4mm

1x 3x
2x

Č.p. 24116

1

DIAMANTOVÝ BRUSNÝ PLÁT

FESTA

60#

· sklo
· křišťál
· keramika
· porcelán
· mramor

150x63x10
mm

Č.p. 22191 hr. 60

Č.p. 22192 hr. 120

Č.p. 22193 hr. 200

05/2026

1

1

1

LED SVÍTELNA MINI

COB 750 lm

1/4"

P8 LED 750 lm

FESTA

750lm

USB
TYPE C

P8 LED
COB

Li-polymer
3.7V
0.45Ah

55g

120min

Č.p. 37655

1

FESTA



FESTA GRIT RUKAVICE PROTIŘEZNÉ

FESTA

CAT II

EN388



4X42C

Rukavice s přidáním protiřezným vláknem, v oblasti dlaně jsou máčené v polyuretanu.



Č.p. 50651	8" M		1
Č.p. 50652	9" L		1
Č.p. 50653	10" XL		1
Č.p. 50654	11" XXL		1

FESTA TWIST RUKAVICE MÁČENÉ V LATEXU

FESTA

CAT II

EN388

EN407



2121X X1XXXX

Rukavice polyesterové s pískovým latexovým povlakem na dlani.



Č.p. 50661	8" M		1
Č.p. 50662	9" L		1
Č.p. 50663	10" XL		1
Č.p. 50664	11" XXL		1

FESTA BRAX RUKAVICE MÁČENÉ V NITRILOVÉ PĚNĚ, S NITRILOVÝMI TERČÍKY



FESTA

CAT II

EN388



4131A

Rukavice nylonové, s nitrilovými nopy v oblasti dlaně.



Č.p. 50610	7" S		1
Č.p. 50611	8" M		1
Č.p. 50612	9" L		1
Č.p. 50613	10" XL		1
Č.p. 50614	11" XXL		1

FESTA NARDO RUKAVICE PROTISKLUZOVÉ

FESTA



Rukavice s pružnou tkaninou na hřbetě, se silikonovými nopy v oblasti dlaně.



Č.p. 50590	10" XL		1
Č.p. 50591	11" XXL		1

FESTA SOREN
RUKAVICE ZIMNÍ,
MÁČENÉ V LATEXOVÉ PĚŇĚ

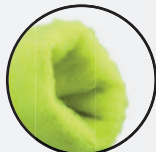

FESTA

CAT II



Rukavice polyesterové, s ochranou proti kontaktnímu chladu, v oblasti dlaně a palce máčené v pískovém latexu.



Č.p. 50642	8" M		1
Č.p. 50643	9" L		1
Č.p. 50645	10" XL		1

FESTA KELT WHITE
RUKAVICE MÁČENÉ V POLYURETANU



FESTA

CAT II



Rukavice z polyesterového úpletu, v oblasti dlaně máčené v polyuretanu.



Č.p. 50683	9" L		1
Č.p. 50684	10" XL		1
Č.p. 50685	11" XXL		1

FESTA KELT BLACK
RUKAVICE MÁČENÉ V POLYURETANU



FESTA

CAT II



Rukavice z polyesterového úpletu, v oblasti dlaně máčené v polyuretanu.



Č.p. 50623	9" L		1
Č.p. 50624	10" XL		1
Č.p. 50625	11" XXL		1

FESTA BRENT
RUKAVICE MÁČENÉ V NITRILU



FESTA

CAT II



Rukavice z polyesterového úpletu, v oblasti dlaně máčené v hladkém nitrilu.



Č.p. 50632	8" M		1
Č.p. 50533	10" XL		1

FESTA DEX
RUKAVICE MÁČENÉ V LATEXOVÉ PĚŇĚ



FESTA

CAT II



Rukavice z polyesterového úpletu, v oblasti dlaně máčené v latexové pěně.



Č.p. 50535	8" M		1
Č.p. 50536	9" L		1
Č.p. 50537	10" XL		1
Č.p. 50538	11" XXL		1

FESTA NORDIN
RUKAVICE ZIMNÍ 3/4,
MÁČENÉ V LATEXOVÉ PĚŇĚ

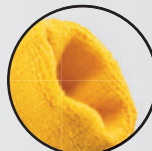

FESTA

CAT II



Rukavice vyrobené z akrylu, v oblasti dlaně jsou máčené v latexové pěně.



Č.p. 50627	8" M		1
Č.p. 50628	9" L		1
Č.p. 50630	11" XXL		1

ZRCÁTKO TELESKOPICKÉ S LED

WESTBERG



290 - 876 mm

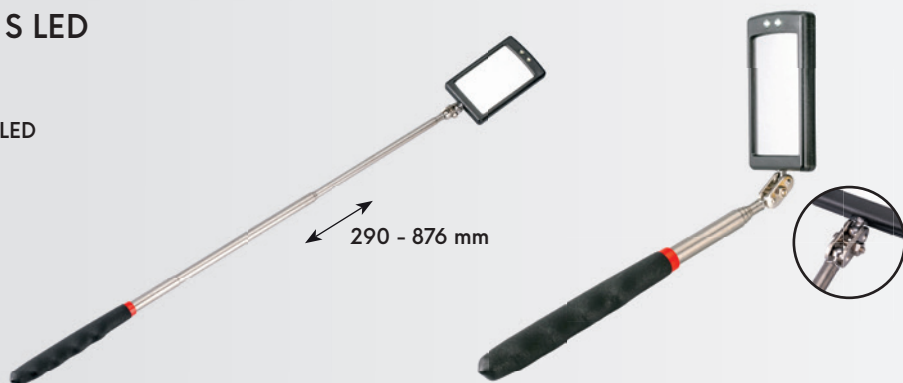

Č.p. 13291

1

VOZÍK TRANSPORTNÍ

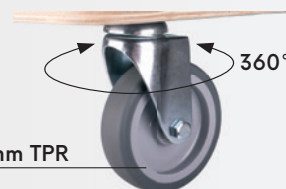

FESTA



Č.p. 23667

1

BATOH NA NÁŘADÍ



FESTA



Č.p. 37335 20l

1

SEKÁČ RÝČOVÝ SDS MAX

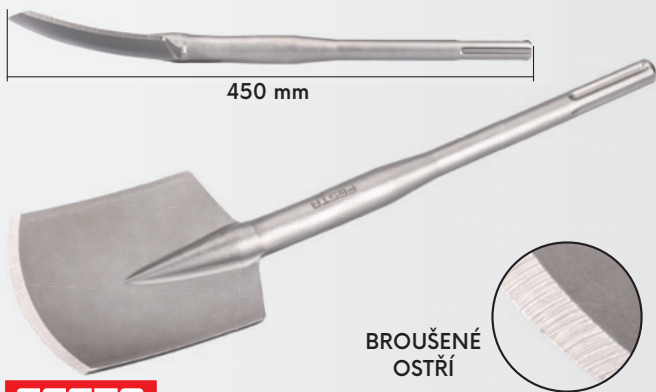

FESTA



Č.p. 20933



SEKÁČ DRÁŽKOVACÍ SDS MAX



FESTA



Č.p. 20931



SEKÁČ PLOCHÝ SDS+



FESTA



Č.p. 20934



SEKÁČ PLOCHÝ SDS+

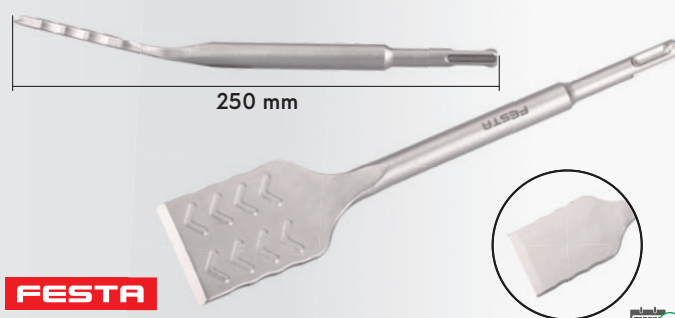

FESTA



Č.p. 20935



SADA SEKÁČŮ SDS+



FESTA



Č.p. 20925



PEMRLICE SDS MAX



FESTA



No. 20993



ADAPTÉR SDS+ NA BRUSNÉ KORUNKY

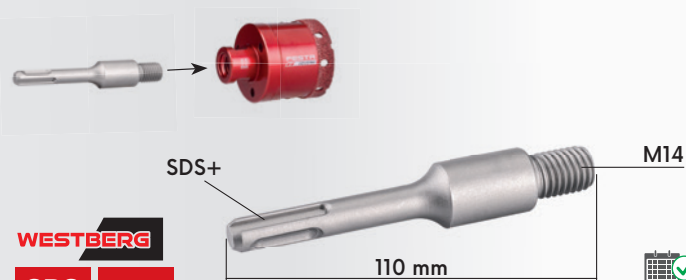

WESTBERG



Č.p. 20719



HLADÍTKO NA BETON



FESTA

405x79mm

Magnesium Alloy



Č.p. 32055

1

HLADÍTKO NEREZ OBLÉ



FESTA

INOX STAINLESS STEEL

300x80mm



05|2026

Č.p. 31135

1

SET NEREZOVÝCH HLADÍTEK S RUKOJETÍ

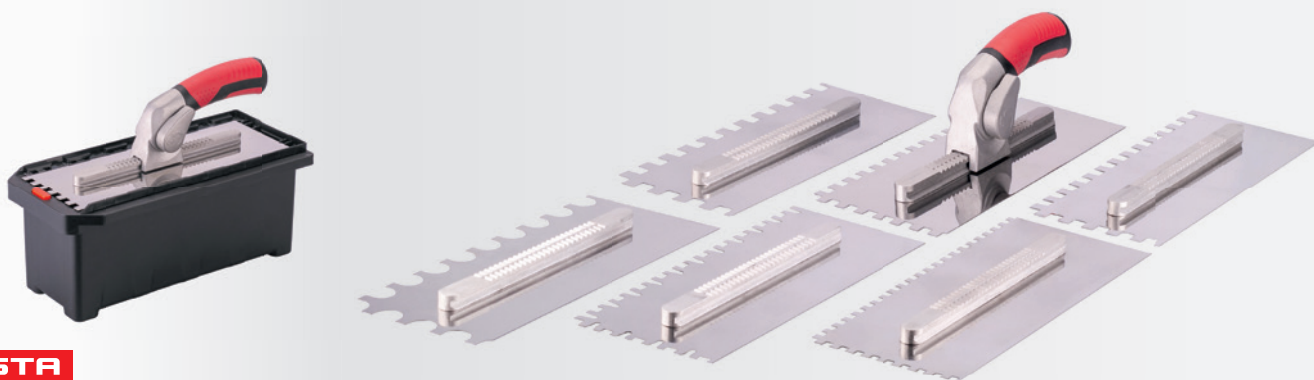

FESTA

6x

ALU

INOX STAINLESS STEEL

280x115mm

6 mm

8 mm

10 mm

12 mm

TIGGER

ø14



06|2026

Č.p. 31160

1

ŠKRABÁK NA POLYSTYREN

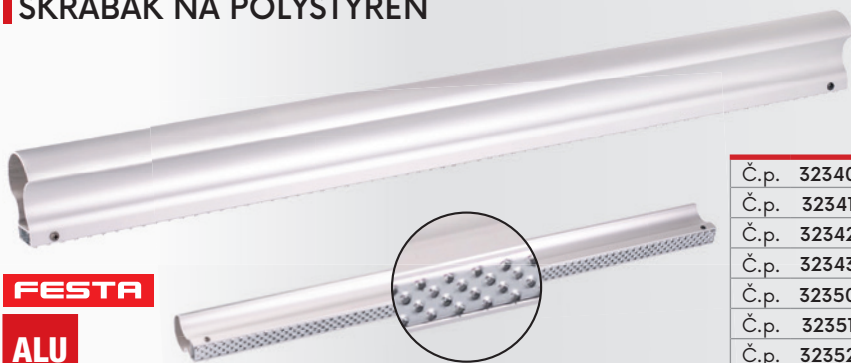

FESTA

ALU



05|2026



Č.p. 32340	800 mm	1
Č.p. 32341	1200 mm	1
Č.p. 32342	1600 mm	1
Č.p. 32343	2000 mm	1
Č.p. 32350	náhradní břít 800 mm	1
Č.p. 32351	náhradní břít 1200 mm	1
Č.p. 32352	náhradní břít 1600 mm	1
Č.p. 32353	náhradní břít 2000 mm	1

NÁHRADNÍ KOLEČKO DO ŘEZAČKY DLAŽBY

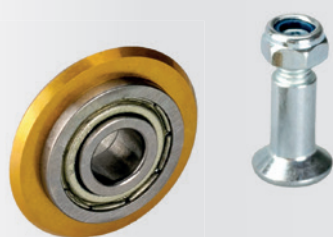
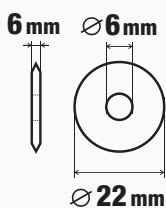

FESTA

TiN

ø 22 mm



36102, 36103, 36105



Č.p. 36139

1

STAVEBNÍ PROVÁZEK ČERVENÝ S BÍLÝMI PRUHY

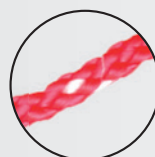

FESTA

high visibility

ø 1.7 mm



Č.p. 38897	1,7 mm x 50 m	1
Č.p. 38898	1,7 mm x 100 m	1

PISTOLE VYTLAČOVACÍ



FESTA
INDUSTRY

300 ml

Č.p. 38033



SPÁROVACÍ STĚRKA



WESTBERG

TPR TERMOPLASTICKÁ PRYŽ



Č.p. 37057



SADA SILIKONOVÝCH STĚREK S RUKOJETÍ 9v1



WESTBERG

10x



Č.p. 37058



MÍCHADLO NA BARVY



WESTBERG

Ø 80 mm 425 mm 8mm



Č.p. 35130



MALÍŘSKÝ ZAKRÝVACÍ FILC S PVC FÓLIÍ

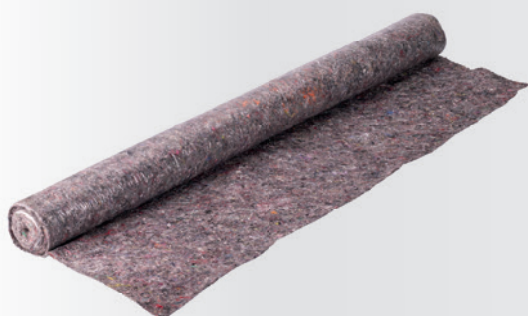
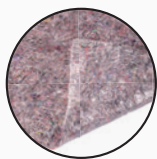

WESTBERG

220
g/m²



Č.p.	37292	1 x 10 m		1
Č.p.	37293	1 x 25 m		1
Č.p.	37294	1 x 50 m		1

FÓLIE ZAKRÝVACÍ ČERNÁ



WESTBERG

4x5
m 50
µm



Č.p.	37254			1
------	-------	--	--	---

VĚDRO



Ø D



Č.p.	39013	12 l	7 mm		1
Č.p.	39022	20 l	7 mm		1
Č.p.	39046	45 l	8 mm		1

ZAKRÝVACÍ PLACHTA - ZELENÁ



100 g/m²



LEPENKA VLNITÁ

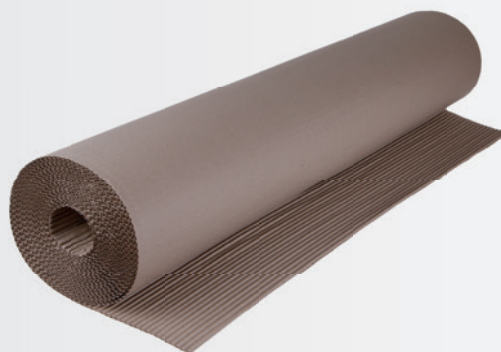

Č.p.	54009	1 x 20 m		1
Č.p.	54010	1 x 30 m		1
Č.p.	54011	1 x 50 m		1

MISKA NA SÁDRU



3,3 l

WESTBERG



Č.p.	37318	ø 224 x 122 mm		1
------	-------	----------------	--	---

VĚDRO S RUČKOU

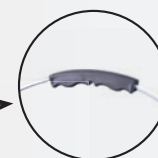

Č.p.	39023	20 l		1
------	-------	------	--	---

Č.p.	25504	2 x 2 m		1
Č.p.	25506	2 x 3 m		1
Č.p.	25512	3 x 4 m		1
Č.p.	25515	3 x 5 m		1
Č.p.	25516	2 x 8 m		1
Č.p.	25520	4 x 5 m		1
Č.p.	25524	4 x 6 m		1
Č.p.	25540	5 x 8 m		1
Č.p.	25560	6 x 10 m		1
Č.p.	25586	8 x 12 m		1
Č.p.	25595	10 x 15 m		1

SVĚRKA BEDNICÍ PRUŽINOVÁ



Č.p. 48501



NAPÍNÁK BEDNICÍCH SVĚREK



Č.p. 48502



PLETIVO HEX - POZINKOVÁNO



Zn
coated



05|2026

Č.p.	42421	13/0,7 x 1000 mm	5 m		1
Č.p.	42422	16/0,7 x 1000 mm	5 m		1
Č.p.	42423	20/0,7 x 1000 mm	5 m		1
Č.p.	42424	25/0,8 x 1000 mm	5 m		1
Č.p.	42425	13/0,7 x 1000 mm	10 m		1
Č.p.	42426	16/0,7 x 1000 mm	10 m		1
Č.p.	42427	20/0,7 x 1000 mm	10 m		1
Č.p.	42428	25/0,8 x 1000 mm	10 m		1

PLETIVO HEX - POTAŽENO PVC



PVC
coated



05|2026

Č.p.	42431	13/1 x 1000 mm	5 m		1
Č.p.	42432	16/1 x 1000 mm	5 m		1
Č.p.	42433	20/1 x 1000 mm	5 m		1
Č.p.	42434	55/1 x 1000 mm	5 m		1
Č.p.	42435	13/1 x 1000 mm	10 m		1
Č.p.	42436	16/1 x 1000 mm	10 m		1
Č.p.	42437	20/1 x 1000 mm	10 m		1
Č.p.	42438	10/1 x 1000 mm	10 m		1

PLETIVO ČTVEREC - POZINKOVÁNO



Zn
coated



05|2026

Č.p.	42441	10/0,8 x 1000 mm	5 m		1
Č.p.	42442	13/0,8 x 1000 mm	5 m		1
Č.p.	42443	16/1,2 x 1000 mm	5 m		1
Č.p.	42444	19/1,4 x 1000 mm	5 m		1
Č.p.	42445	25/1,4 x 1000 mm	5 m		1
Č.p.	42446	10/0,8 x 1000 mm	10 m		1
Č.p.	42447	13/0,8 x 1000 mm	10 m		1
Č.p.	42448	16/1,2 x 1000 mm	10 m		1
Č.p.	42449	19/1,4 x 1000 mm	10 m		1
Č.p.	42450	25/1,4 x 1000 mm	10 m		1

PLETIVO ČTVEREC - POTAŽENO PVC

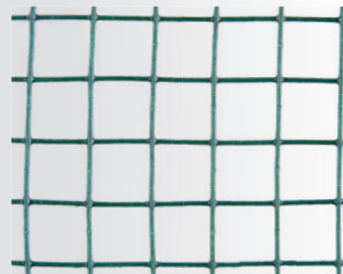

PVC
coated



05|2026

Č.p.	42451	13/1,2 x 1000 mm	5 m		1
Č.p.	42452	16/1,2 x 1000 mm	5 m		1
Č.p.	42453	5/2,3 x 1000 mm	5 m		1
Č.p.	42455	13/1,2 x 1000 mm	10 m		1
Č.p.	42456	16/1,2 x 1000 mm	10 m		1
Č.p.	42457	10/2,3 x 1000 mm	10 m		1

SEKERA MONOLIT



FESTA

Č.p. 19302 600 g



1

VYPICHOVAČ PLEVELE



320 mm carbon steel

Č.p. 45078



1

KLEŠŤOVÉ RYPADLO



HRC 37-48 **150 cm**

Č.p. 61159



1

VENTIL MRAZUVZDORNÝ ZAHRADNÍ 1/2"

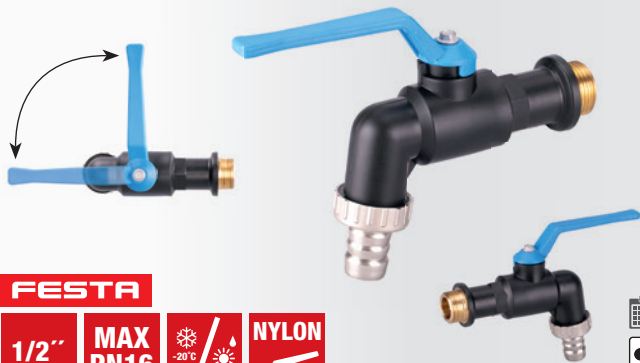

FESTA

1/2" **MAX PN16**



NYLON



1

Č.p. 45103

1

MEZIKUS SPOJOVACÍ PRO 3 RYCHLOSPOJKY



FESTA AQUATIC

10 bar max



Č.p. 45404

1

MEZIKUS SPOJOVACÍ PRO 2 RYCHLOSPOJKY



FESTA AQUATIC

10 bar max



Č.p. 45405

1

STOP RYCHLOSPOJKA 1/2" + 3/4"



FESTA AQUATIC

10 bar max

1/2" + 3/4"



Č.p. 45407

1

RYCHLOSPOJKA 1/2" + 3/4"

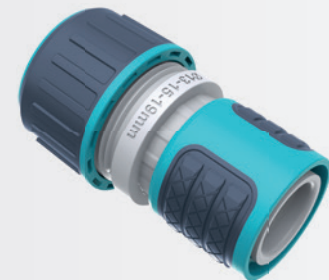

FESTA AQUATIC

10 bar max

1/2" + 3/4"



Č.p. 45406

1

SPOJKA 1/2" + 3/4"



FESTA AQUATIC

10 bar max

1/2" + 3/4"



Č.p. 45408

1

NOVÁ ZNAČKA

NOVÁ ŘADA ZAHRADNÍHO NÁŘADÍ

FESTA
Garden

KOMFORTNÍ
ERGONOMICKÉ
RUKOJETI



ČEPELE
Z OCELI S5
PRO
PRECIZNÍ STŘIH



EFEKTIVNÍ
PŘEVODOVÝ
SYSTÉM



ATRAKTIVNÍ
BAREVNÉ
PROVEDENÍ



FESTA
Garden

NŮŽKY ZAHRADNICKÉ, PŘEVODOVÉ



EXTRA
EASY
CUT

FESTA
Garden



205
mm

SK5



TEFLON



max
25mm

Č.p. 44811

06/2026

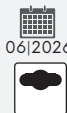

NŮŽKY ZAHRADNICKÉ

FESTA
Garden



215
mm

SK5



TEFLON



max
20mm

Č.p. 44821

06/2026



NŮŽKY ZAHRADNICKÉ

FESTA
Garden



205
mm

SK5



TEFLON



max
20mm

Č.p. 44823

06/2026



NŮŽKY ZAHRADNICKÉ

FESTA
Garden



185
mm

SK5



TEFLON



max
15mm

Č.p. 44824

06/2026



NŮŽKY NA VĚTVY TELESKOPICKÉ

FESTA Garden

705-945 mm SK5 TEFLON max 50mm

Č.p. 44841

1

NŮŽKY NA VĚTVY

FESTA Garden

720 mm SK5 TEFLON max 50mm

Č.p. 44843

1

NŮŽKY NA ŽIVÝ PLOT TELESKOPICKÉ

FESTA Garden

720-965 mm SK5

20 cm

720-965 mm

Č.p. 44845

1

NŮŽKY NA ŽIVÝ PLOT

FESTA Garden

630 mm SK5

22 cm

Č.p. 44847

1

NŮŽKY OTOČNÉ NA TRÁVU



FESTA
Garden

348 mm SK5 360°

Č.p. 44833

1

LOPATKA ZAHRADNÍ ŠIROKÁ



FESTA
Garden

340 mm Al EXTRA LIGHT

Č.p. 44861

1

LOPATKA ZAHRADNÍ ÚZKÁ



FESTA
Garden

340 mm Al EXTRA LIGHT

Č.p. 44862

1

PILA ZAHRADNÍ, ZAVÍRACÍ

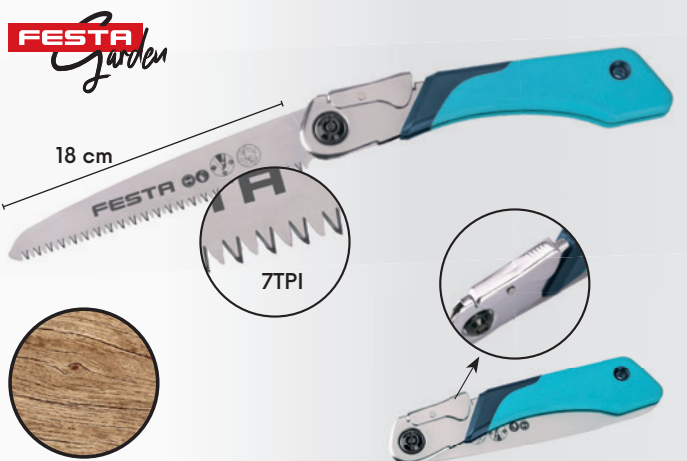

FESTA
Garden

18 cm

7TPI

SK5 7TPI 180mm 1,2mm 1x 2x 3x

05/2026

Č.p. 45072

1

VYTRHÁVAČ PLEVELE



FESTA
Garden

98 - 118 cm

Č.p. 44956

1

REJSTRÍK POLOŽEK

číslo položky	str.	číslo položky	str.	číslo položky	str.	číslo položky	str.	číslo položky	str.	číslo položky	str.
28026	1	22885	13	21653	14	21973	18	50538	25	25586	30
28023	1	22890	13	21654	14	21981	18	50683	25	25595	30
28601	2	22895	13	21655	14	21982	18	50684	25	48501	31
28671	2	22900	13	21656	14	21983	18	50685	25	42421	31
28640	2	22902	13	21657	14	21991	18	50632	25	42422	31
28625	3	22905	13	21658	14	21992	18	50533	25	42423	31
28681	3	22911	13	21659	14	21993	18	50627	25	42424	31
28682	3	22915	13	21660	14	17690	19	50628	25	42425	31
28620	3	22922	13	21661	14	17691	19	50630	25	42426	31
28678	3	22925	13	21662	14	17270	20	13291	26	42427	31
28679	3	22930	13	21663	14	17271	20	23667	26	42428	31
28630	4	20501	13	21664	14	17273	20	37335	26	42441	31
28635	4	20502	13	21665	14	17274	20	20933	27	42442	31
28615	5	20503	13	21666	14	17073	20	20934	27	42443	31
28675	5	20504	13	21667	14	18595	20	20925	27	42444	31
28676	5	21610	14	21668	14	18726	20	20993	27	42445	31
28610	5	21611	14	21669	14	18727	20	20931	27	42446	31
28684	5	21612	14	21670	14	18597	20	20935	27	42447	31
28235	6	21613	14	21671	14	18436	21	20719	27	42448	31
22338	6	21614	14	21672	14	17263	21	32055	28	42449	31
70042	7	21615	14	21673	14	17265	21	31160	28	42450	31
35355	7	21616	14	21674	14	18616	21	36139	28	48502	31
28079	8	21617	14	21675	14	14413	22	31135	28	42431	31
36330	8	21618	14	20392	15	16027	22	32340	28	42432	31
36333	8	21619	14	21542	15	24013	22	32341	28	42433	31
36334	8	21620	14	21822	15	15750	22	32342	28	42434	31
35349	8	21621	14	21538	15	24012	22	32343	28	42435	31
28270	9	21622	14	24817	15	16318	23	32350	28	42436	31
28272	9	21623	14	24818	15	24116	23	32351	28	42437	31
28348	10	21624	14	24820	15	37655	23	32352	28	42438	31
45274	10	21625	14	24824	15	22157	23	32353	28	42451	31
28283	10	21626	14	24317	15	22191	23	38897	28	42452	31
28347	10	21610	14	24318	15	22192	23	38898	28	42453	31
28349	10	21628	14	21240	16	22193	23	38033	29	42455	31
45276	10	21629	14	21243	16	50651	24	37057	29	42456	31
18438	10	21630	14	21256	16	50652	24	35130	29	42457	31
26212	11	21631	14	21246	16	50653	24	37058	29	19302	32
26227	11	21632	14	21260	16	50654	24	37292	30	45078	32
26225	11	21633	14	21778	17	50610	24	37293	30	61159	32
26229	12	21634	14	31615	17	50611	24	37294	30	45103	32
26223	12	21635	14	21843	17	50612	24	37254	30	45404	32
26206	12	21636	14	21771	17	50613	24	39013	30	45405	32
26222	12	21637	14	21775	17	50614	24	39022	30	45407	32
22830	13	21638	14	21558	17	50661	24	39046	30	45406	32
22833	13	21639	14	21560	17	50662	24	54009	30	45408	32
22835	13	21640	14	21562	17	50663	24	54010	30	44811	34
22840	13	21641	14	21565	17	50664	24	54011	30	44821	34
22842	13	21642	14	21568	17	50590	24	37318	30	44823	34
22845	13	21643	14	21961	18	50591	24	39023	30	44824	34
22848	13	21644	14	21965	18	50642	25	25504	30	44841	35
22850	13	21645	14	21966	18	50643	25	25506	30	44843	35
22855	13	21646	14	21967	18	50645	25	25512	30	44845	35
22860	13	21647	14	21975	18	50623	25	25515	30	44847	35
22865	13	21648	14	21985	18	50624	25	25516	30	44833	36
22868	13	21649	14	21962	18	50625	25	25520	30	44861	36
22870	13	21650	14	21963	18	50535	25	25524	30	44862	36
22875	13	21651	14	21971	18	50536	25	25540	30	45072	36
22880	13	21652	14	21972	18	50537	25	25560	30	44956	36

2026



festatools



#festatools



festatools

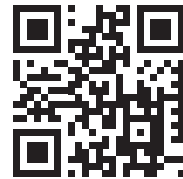

www.festa.tools

HORIZONT.

FESTA
POWER X TOOLS

FESTA
AQUATIC

KDS KOMELON®

ROSA

Stahlberg

Lescha SUPER PRO

